



2/2

195674
763918

FR ENVIRONNEMENT EXTENSIBLE L140/160 CM "WATSON"
CHENE KRONBERG/CHENE WATERFORD
MEUBLE A USAGE DOMESTIQUE EN PANNEAUX DE PARTICULES A MONTER SOI-MEME.

EN EXTENDABLE HEAD-BED 140/160 CM "WATSON"
KRONBERG OAK/WATERFORD
HOUSE FURNITURE IN CHIPBOARD - READY TO ASSEMBLY.

DE BETTKASTENELEMENT VERGROSSERBAR 140/160CM "WATSON"
KRONBERG EICH/WATERFORD
NUR ZUM HAEUSLICHEM GEBRAUCH AUS SPANPLATTEN ZUM SELBSTERBAU.

ES CABEZAL CAMA EXTENSIBLE 140/160 CM "WATSON"
ROBLE KRONBERG/WATERFORD
MUEBLE A USO DOMESTICO EN AGLOMERADO PARA ARMAR.

NL UITBREIDING BEDKAST 140/160 CM "WATSON"
EIK KRONBERG/WATERFORD
SPAANPLATENMEUBEL VOOR EIGEN GEBRUIK OM ZELF TE MONTEREN.

IT RETROLETTO ESTENSIBILE 140/160 CM "WATSON"
QUERCIA KRONBERG/WATERFORD
MOBILE IN KIT PER ABITAZION IN PANNELLI TRUCIOLATI DA MONTARE.

PT CABECA CAMA EXTENSIVEL 140/160 CM "WATSON"
CARVALHO KRONBERG/WATERF.
MOVEL A USO DOMESTICO EN PAINEL DE PARTICULA A MONTAR SU MISMO.

AR محيط سرير قابل للتوسيع 160/140 سم "واتسون"
بلوط كرونبرغ/واترفورد
الأثاث لوحة الجسيمات ذاتية التجميع للاستخدام المنزلي

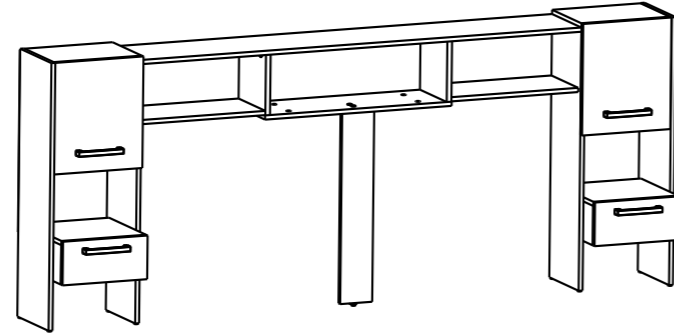

363 mm
14 05/16"
950 mm
37 06/16"
2399 mm
94 07/16"

195674
763918

FABRIQUÉ EN/MADE IN
FRANCE

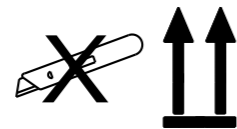

Fabriqué par / Made by
Demeyere
Rue de la prévôté 59840 PERENCHIES (France)



(8006)033977019567410202(20)00(10)05326



2/2

195674
763918

FR ENVIRONNEMENT EXTENSIBLE L140/160 CM "WATSON"
CHENE KRONBERG/CHENE WATERFORD
MEUBLE A USAGE DOMESTIQUE EN PANNEAUX DE PARTICULES A MONTER SOI-MEME.

EN EXTENDABLE HEAD-BED 140/160 CM "WATSON"
KRONBERG OAK/WATERFORD
HOUSE FURNITURE IN CHIPBOARD - READY TO ASSEMBLY.

DE BETTKASTENELEMENT VERGROSSERBAR 140/160CM "WATSON"
KRONBERG EICH/WATERFORD
NUR ZUM HAEUSLICHEM GEBRAUCH AUS SPANPLATTEN ZUM SELBSTERBAU.

ES CABEZAL CAMA EXTENSIBLE 140/160 CM "WATSON"
ROBLE KRONBERG/WATERFORD
MUEBLE A USO DOMESTICO EN AGLOMERADO PARA ARMAR.

NL UITBREIDING BEDKAST 140/160 CM "WATSON"
EIK KRONBERG/WATERFORD
SPAANPLATENMEUBEL VOOR EIGEN GEBRUIK OM ZELF TE MONTEREN.

IT RETROLETTO ESTENSIBILE 140/160 CM "WATSON"
QUERCIA KRONBERG/WATERFORD
MOBILE IN KIT PER ABITAZION IN PANNELLI TRUCIOLATI DA MONTARE.

PT CABECA CAMA EXTENSIVEL 140/160 CM "WATSON"
CARVALHO KRONBERG/WATERF.
MOVEL A USO DOMESTICO EN PAINEL DE PARTICULA A MONTAR SU MISMO.

AR محيط سرير قابل للتوسيع 160/140 سم "واتسون"
بلوط كرونبرغ/واترفورد
الأثاث لوحة الجسيمات ذاتية التجميع للاستخدام المنزلي

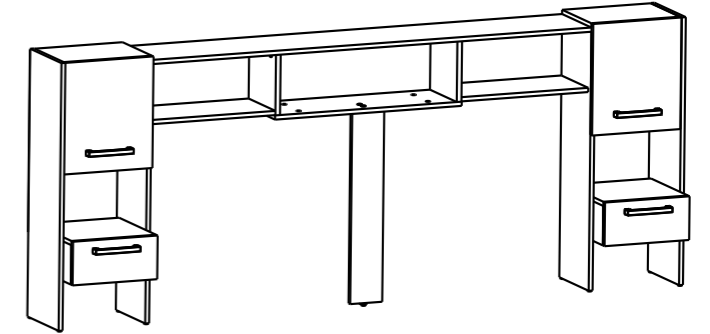

363 mm
14 05/16"
950 mm
37 06/16"
2399 mm
94 07/16"

195674
763918

FABRIQUÉ EN/MADE IN
FRANCE

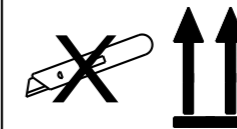
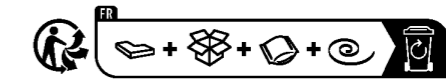

Fabriqué par / Made by
Demeyere
Rue de la prévôté 59840 PERENCHIES (France)

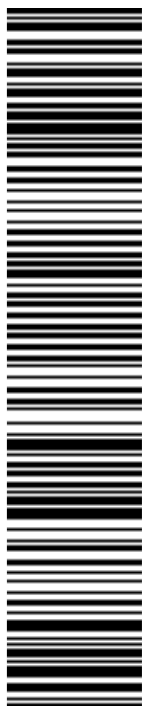

(8006)033977019567410202(20)00(10)05326



2/2

Poids Brut / GW : 16.10Kgs / 35.49Lbs
Poids Net / NW : 15.08Kgs / 33.25Lbs



2/2

Poids Brut / GW : 16.10Kgs / 35.49Lbs
Poids Net / NW : 15.08Kgs / 33.25Lbs